

REMOVAL

1. **DISCONNECT CABLE FROM NEGATIVE BATTERY TERMINAL**
2. **REMOVE REAR WHEEL**
3. **DRAIN BRAKE FLUID**
HINT:
Immediately wash off any brake fluid that comes into contact with any painted surfaces.
4. **DRAIN DIFFERENTIAL OIL**
5. **REMOVE REAR DISC BRAKE CALIPER ASSEMBLY LH (See page [AH-19](#))**
6. **REMOVE REAR DISC BRAKE CALIPER ASSEMBLY RH**
HINT:
Use the same procedure as for the LH side.
7. **REMOVE REAR DISC (See page [PB-17](#))**
8. **REMOVE PARKING BRAKE SHOE RETURN TENSION SPRING (See page [PB-17](#))**
9. **REMOVE PARKING BRAKE SHOE STRUT LH (See page [PB-17](#))**
10. **REMOVE PARKING BRAKE SHOE (See page [PB-17](#))**
11. **SEPARATE PARKING BRAKE CABLE LH (See page [AH-19](#))**
12. **REMOVE PARKING BRAKE CABLE RH**
HINT:
Use the same procedure as for the LH side.
13. **REMOVE REAR SPEED SENSOR (See page [BC-198](#))**
14. **REMOVE REAR SPEED SENSOR RH**
HINT:
Use the same procedure as for the LH side.
15. **REMOVE REAR AXLE SHAFT RH (See page [AH-19](#))**
16. **REMOVE REAR AXLE SHAFT LH**
HINT:
Use the same procedure as for the LH side.
17. **REMOVE REAR AXLE SHAFT LH OIL SEAL (See page [AH-20](#))**
18. **REMOVE REAR AXLE SHAFT RH OIL SEAL**
HINT:
Use the same procedure as for the LH side.
19. **REMOVE REAR PROPELLER SHAFT ASSEMBLY (for 2WD) (See page [PR-9](#))**
20. **REMOVE PROPELLER SHAFT ASSEMBLY (for 4WD) (See page [PR-9](#))**

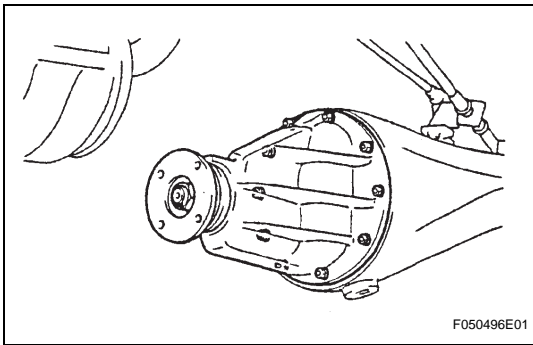

21. REMOVE REAR DIFFERENTIAL CARRIER ASSEMBLY

- (a) Remove the 10 nuts and the differential carrier.

NOTICE:

Be careful not to damage the contact surface.

22. REMOVE REAR DIFFERENTIAL CARRIER GASKET

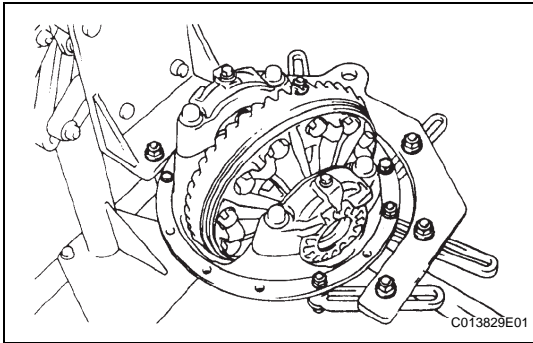

DISASSEMBLY

1. FIX REAR DIFFERENTIAL CARRIER ASSEMBLY

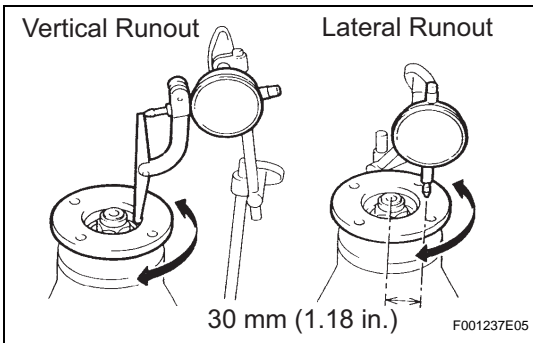

2. INSPECT RUNOUT OF REAR DRIVE PINION COMPANION FLANGE SUB-ASSEMBLY REAR

- (a) Using a dial indicator, measure the runout of the companion flange vertically and laterally.

Maximum runout

Runout	Maximum
Vertical runout	0.10 mm (0.0039 in.)
Lateral runout	0.10 mm (0.0039 in.)

If the runout is greater than the maximum, replace the companion flange.

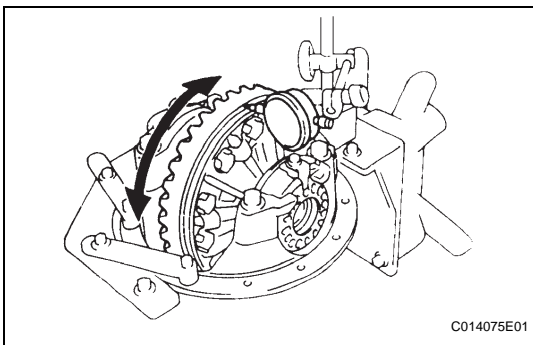

3. INSPECT RUNOUT OF DIFFERENTIAL RING GEAR

- (a) Using a dial indicator, check the runout of the ring gear.

Maximum runout:

0.07 mm (0.0028 in.)

If the runout is greater than the maximum, replace the ring gear with a new one.

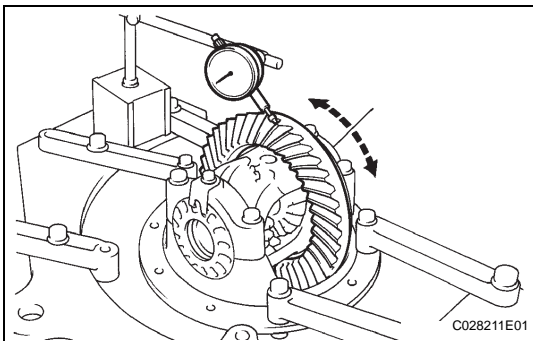

4. INSPECT DIFFERENTIAL RING GEAR BACKLASH

- (a) Using a dial indicator, check the backlash of the ring gear.

Backlash:

0.13 to 0.18 mm (0.0051 to 0.0071 in.)

If the backlash is not within the specification, adjust the side bearing preload or repair as necessary.

HINT:

Perform the measurements at 3 or more positions around the side bearing preload.

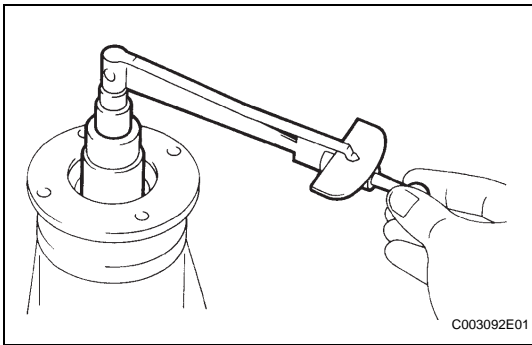
**5. INSPECT DIFFERENTIAL DRIVE PINION PRELOAD**

- (a) Using a torque wrench, measure the preload of backlash between the drive pinion and ring gear.

Preload (at starting):

0.56 to 0.85 N*m (5.7 to 8.7 kgf*cm, 5.0 to 7.5 in.*lbf)

If necessary, disassemble and inspect the differential.

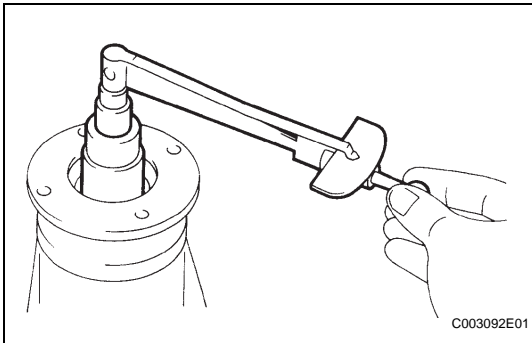
**6. INSPECT TOTAL PRELOAD**

- (a) Using a torque wrench, measure the preload with the teeth of the drive pinion and ring gear in contact.

- (b) Using a torque wrench, measure the total preload.

Total preload (at starting):

Drive pinion preload plus 0.39 to 0.59 N*m (4.0 to 6.0 kgf*cm, 3.5 to 5.2 in.*lbf)

If necessary, disassemble and inspect the differential.

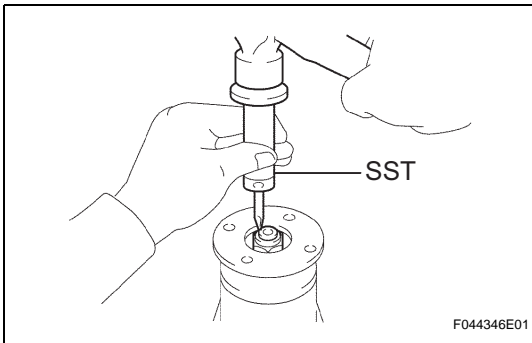
**7. REMOVE REAR DRIVE PINION NUT**

- (a) Using SST and a hammer, loosen the staked part of the nut.

SST 09930-00010

- (b) Using SST to hold the companion flange in place, remove the nut.

SST 09330-00021

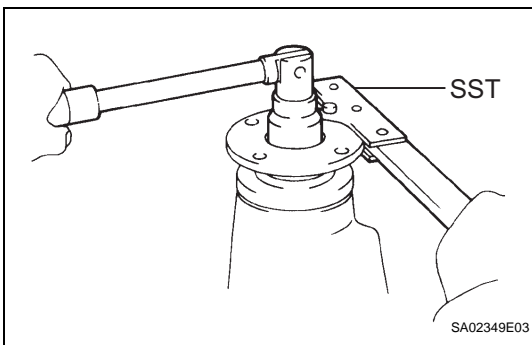
**8. REMOVE REAR DRIVE PINION COMPANION FLANGE SUB-ASSEMBLY**

- (a) Using SST, remove the companion flange.

SST 09950-30012 (09951-03010, 09953-03010, 09954-03010, 09955-03030, 09956-03030)

NOTICE:

Before using SST (center bolt), apply hypoid gear oil to its threads and tip.

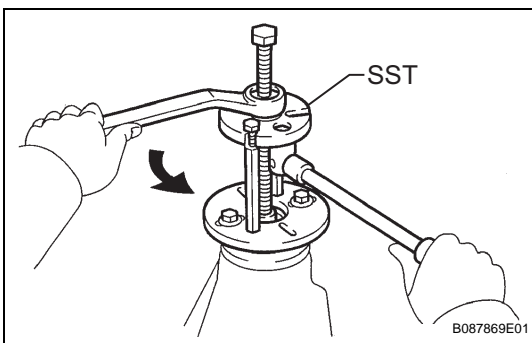

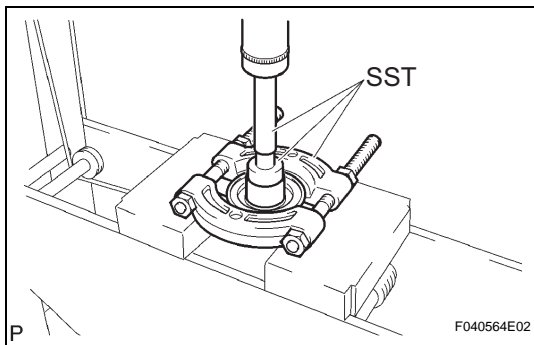

- 9. REMOVE REAR DIFFERENTIAL DUST DEFLECTOR**
 (a) Using SST and a press, press out the dust deflector.
SST 09950-60010 (09951-00380), 09950-70010 (09951-07150), 09950-00020

NOTICE:
 Do not drop the companion flange.

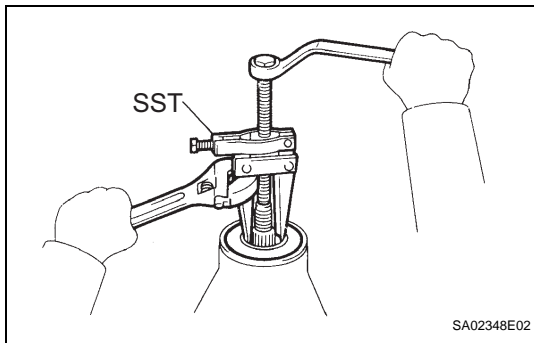

- 10. REMOVE REAR DIFFERENTIAL CARRIER OIL SEAL**
 (a) Using SST, remove the oil seal from the differential carrier.
SST 09308-10010

- 11. REMOVE REAR DIFFERENTIAL DRIVE PINION OIL SLINGER**

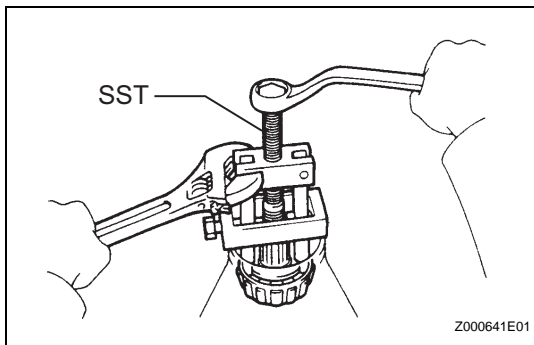

- 12. REMOVE REAR DRIVE PINION FRONT TAPERED ROLLER BEARING**
 (a) Using SST, remove the roller bearing (inner) from the drive pinion.
SST 09556-22010

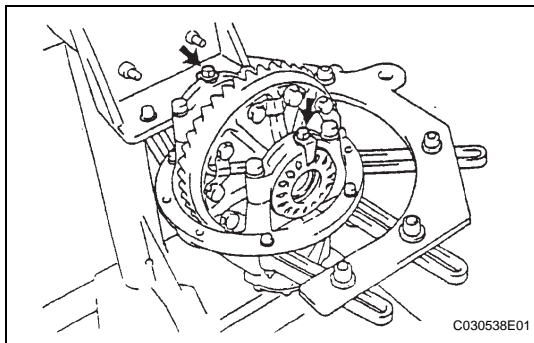

- 13. REMOVE REAR DIFFERENTIAL BEARING ADJUSTING NUT LOCK**
 (a) Remove the 2 bolts and 2 adjusting locks.

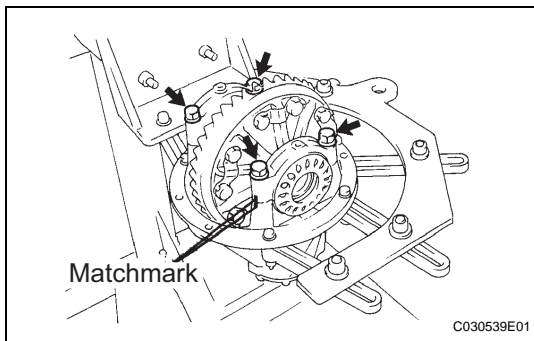

- 14. REMOVE DIFFERENTIAL CASE ASSEMBLY**
 (a) Place matchmarks on the bearing cap and differential carrier.
 (b) Remove the 4 bolts and 2 differential bearing caps.
 (c) Remove the 2 adjusting nuts.

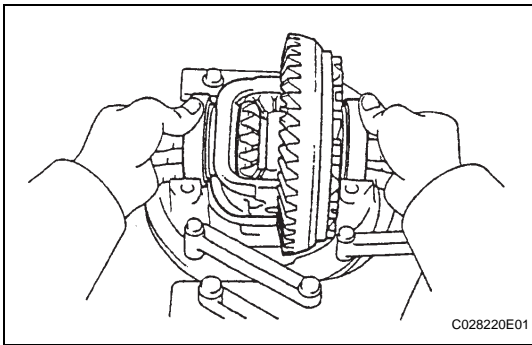

- (d) Remove the rear differential case assembly from the differential carrier.

HINT:

Tag the 2 case bearing outer races to show the location for reassembly.

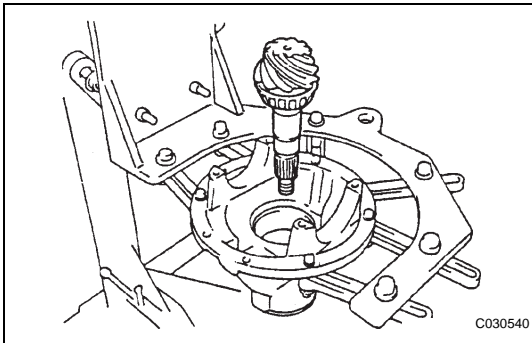

15. REMOVE DIFFERENTIAL DRIVE PINION

- (a) Remove the drive pinion and bearing spacer from the differential carrier.

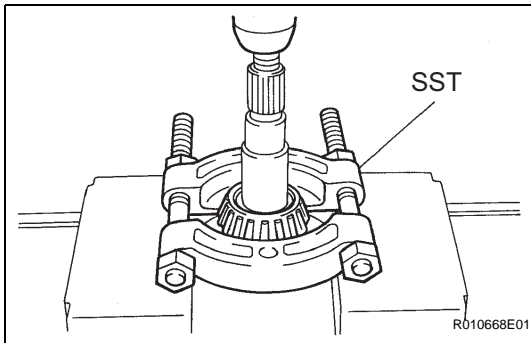

16. REMOVE REAR DRIVE PINION REAR TAPERED ROLLER BEARING

- (a) Using SST and a press, press out the roller bearing (inner) from the drive pinion.

SST 09950-00020

NOTICE:

Do not drop the drive pinion.

HINT:

If the drive pinion or ring gear is damaged, replace them as a set.

17. REMOVE REAR DIFFERENTIAL DRIVE PINION PLATE WASHER

18. REMOVE REAR DRIVE PINION FRONT TAPERED ROLLER BEARING

- (a) Using SST, remove the roller bearing (outer) from the carrier.

SST 09308-00010

- (b) Using a brass bar and hammer, tap out the oil storage ring from the carrier.

HINT:

If the bearing is damaged during removal, replace it.

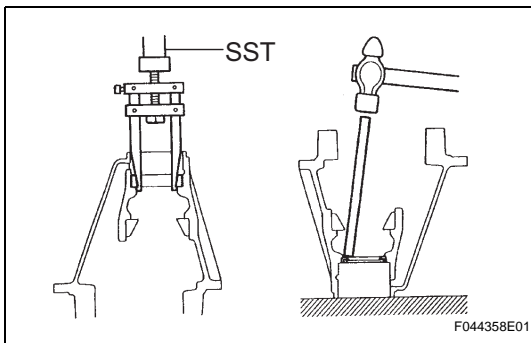

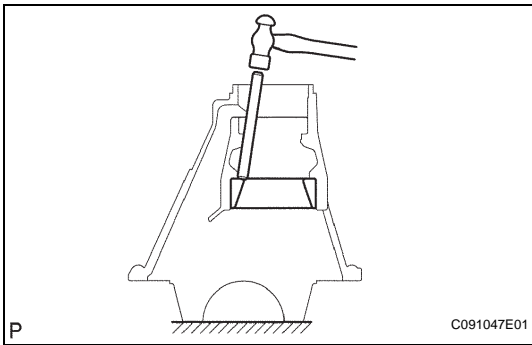

19. REMOVE REAR DRIVE PINION REAR TAPERED ROLLER BEARING

- (a) Using a brass bar and hammer, tap out the rear tapered roller bearing (outer) from the carrier.
HINT:
If the bearing is damaged during removal, replace it.

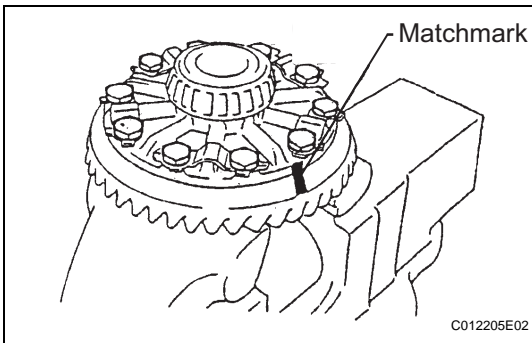

20. REMOVE DIFFERENTIAL RING GEAR

- (a) Place matchmarks on the ring gear and differential case.
(b) Using a screwdriver and hammer, pry out the lock plates.
(c) Remove the 10 ring gear set bolts and 5 lock plates.

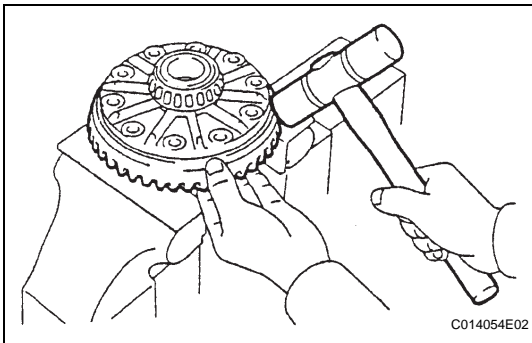

- (d) Using a plastic-faced hammer, tap on the ring gear to separate it from the differential case.

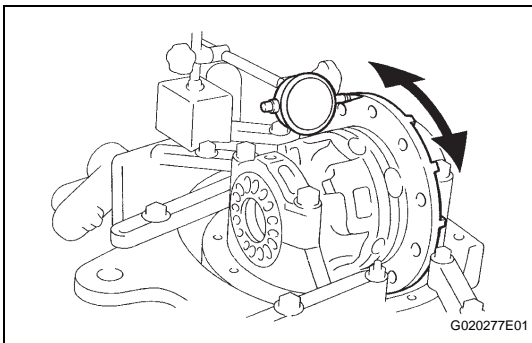

21. INSPECT DIFFERENTIAL CASE ASSEMBLY RUNOUT

- (a) Install the rear differential case bearing onto the differential case.
(b) Install the differential case onto the differential carrier.
(c) Install the 2 bearing caps onto the differential carrier with the 4 bolts.

Torque: 85 N*m (870 kgf*cm, 63 ft.*lbf)

- (d) Using a dial indicator, measure the differential case runout.

Maximum runout:

0.07 mm (0.0028 in.)

- (e) Remove the differential case.
(f) Remove the rear differential case bearing.

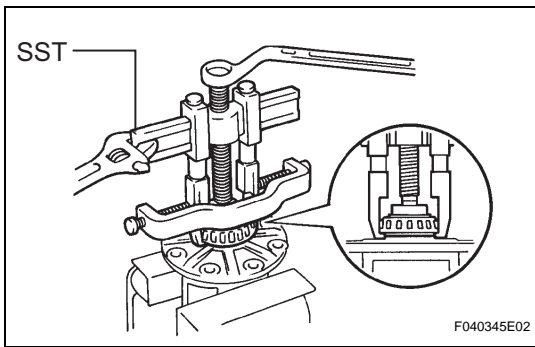

22. REMOVE REAR DIFFERENTIAL CASE BEARING

- (a) Using SST, remove the 2 bearings from the differential case.

SST 09950-40011 (09951-04020, 09952-04010, 09953-04030, 09954-04010, 09955-04061, 09957-04010, 09958-04011), 09950-60010 (09951-00360)

HINT:

Do not remove the case bearing unless replacing the differential case.

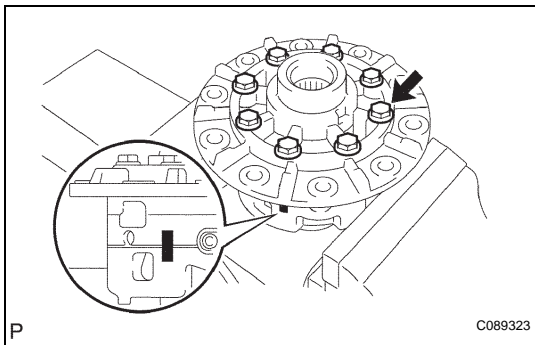

23. DISASSEMBLE DIFFERENTIAL CASE

- (a) Place matchmarks on the LH and RH cases.
- (b) Remove the 8 bolts.

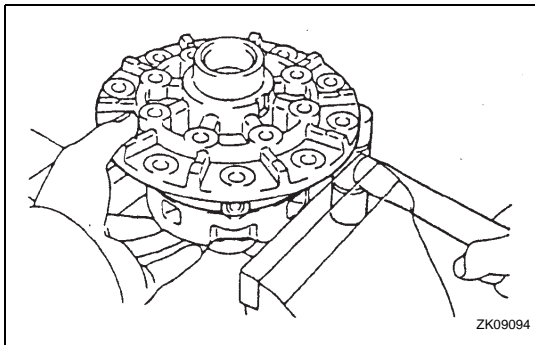

- (c) Using a plastic hammer, separate the LH and RH cases.

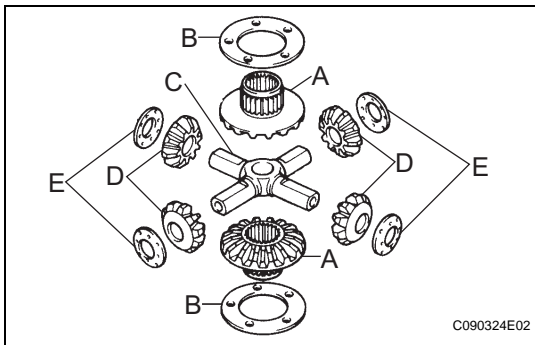

- (d) Remove the following parts from the differential case.

A	Side gear
B	Side gear thrust washer
C	Spider
D	Pinion gear
E	Pinion gear thrust washer